

 **TOYOTA HIACE**
oh what a *feeling!*

The Trademark of the Professional.





Yaris



Corolla



Prius



RAV4



Camry



Aurion



Avenis



Kluger



Tarago



Prado



Landcruiser 200 Series



Hilux



Landcruiser 70 Series

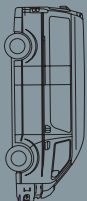

HiAce Commuter Bus

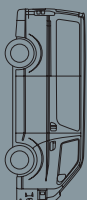

HiAce Van



Coaster

HiAce has been building its reputation for longer than most have been building their businesses. And as any professional knows, when you build a better product, people stick with you.

For over sixteen years, HiAce has been the most respected van in the trade with over 3.7m vehicles sold. Toyota listened to what buyers wanted now and in the future, whether government, fleet or private operators and set out to build a van that would meet the high demands of its operators. HiAce is built to carry more and work harder than ever before, yet it's even nicer to get along with, because you're going to be spending a lot of time aboard this HiAce.

The engines are powerful, yet efficient. Longer service intervals for diesel engines reduce downtime, plus, petrol engines are LPG compatible for even greater flexibility. In the Long Wheelbase (LWB) and the Super Long Wheelbase (SLWB), there's more cargo carrying capacity than ever. The Commuter Bus has plenty of comfort features and carries 14 adults including the driver.

With typical Toyota Quality, Durability and Reliability (QDR), this is the vehicle you can stake your livelihood on. And wearing the HiAce badge, it projects a look of professionalism to your customers that will take your business to another level.

HiAce

Clever ideas for a better tomorrow.
When will we ever be satisfied?





When will we ever be satisfied? The truth is, our designers and engineers never will. As soon as they've come up with one great idea, they're busy creating an even better one. The Japanese call this 'Kaizen' ('continuous improvement'). A constant flow of great ideas is the result. There are already Toyota models that talk to you, guiding you home by voice using advanced DVD based satellite-linked technologies. We have the Hybrid Synergy Drive System (HSD) in the Prius. It combines petrol and electric power to halve green house gas emissions whilst doubling fuel economy.* Just wait, we plan to roll out HSD across a range of Toyota models in the near future.

Even today, advanced engine technologies like VVT-i (Variable Valve Timing with intelligence) petrol engines in most Toyotas are giving immediate benefits in performance, economy and emissions. Right now, we can also help make you feel like an expert driver off road in a 4WD vehicle equipped with 'Driver Assist Technology'. We can keep you connected with friends via our Bluetooth™ hands-free mobile communications technology. You can also get immediate help using the Toyota Link communication system on Aurion Presara.

We'll even help you feel more positive about our planet's future. Our environmental program known as the 'Toyota Earth Charter' has lots of great ideas. It outlines visionary environmental objectives to guide Toyota worldwide. As a result, every new Toyota undergoes an assessment aimed at minimising its environmental impact for life. Toyota manufacturing is getting cleaner as well. Our Melbourne plant uses great ideas like waterborne paint, reducing solvent emissions. We also had the idea to develop recyclable plastics like Toyota Super Olefin Polymer and Toyota Eco-Plastic which overcome traditional recycling difficulties.

Best of all, the car you're looking at right now is filled with ideas like these – ideas that not only make motoring easier, they'll make your life a whole lot more fun and exciting as well.

In fact, it's little wonder at Toyota we're incredibly optimistic about the future. Imagine this: Racing around in a 4WD off-roader called the Rugged Sports Coupe (RSC). With its modern "rugged" design cues this concept was created through extensive research of off track racing formats drawing on both Toyota's 4WD Heritage and our long history in the World Rally Championships (WRC).

You'll also feel safer in the future as we pursue our dream of a zero accident motoring environment. Innovations like radar cruise control will keep your car travelling a safe distance from the one ahead, even in stop-start traffic. At night, infra-red technology will help you see obstacles on the road ahead, way beyond the range of your eyesight. We're even building cars that sense impending collisions and prepare themselves to maximise occupant protection.

We have so many great ideas for you just around the corner that you'll feel that you
"Can't Wait for Tomorrow."

CAN'T WAIT FOR TOMORROW



toyota.com.au

*ADR81/01 combined cycle. Actual Fuel consumption may vary depending on driving style and conditions.





Super Long Wheel Base model shown.





The power of high technology.

HiAce will move you and your load with two reliable engines, and they'll perform with impressive efficiency, vital in today's competitive business world where reduced running costs add up to greater profitability. You have the choice of a twin cam VVT-i equipped 2.7 litre petrol engine which is LPG compatible or a hard-working 3.0 litre turbocharged intercooled common rail diesel.

Advanced technology petrol engine.

The 2.7 litre petrol engine is the first twin overhead cam petrol engine in a HiAce. Variable Valve Timing with intelligence (VVT-i), normally only found in passenger cars, ensures greater flexibility and performance. This is especially helpful when driving a heavily laden vehicle. Peak power of 111kW comes in at a relatively low 4,800rpm with 241Nm of load-lugging torque at 3,800rpm. Twin counter-rotating balance shafts reduce vibration for smoother, quieter running. Countless innovations are also to be found throughout the engine, from the injection to the valve gear to the ignition system. What hasn't Toyota done to maximise engine efficiency and reduce friction emissions? The 2.7 litre petrol engine also meets strict Euro IV emissions requirements and ensures increased reliability and less maintenance down the track.

A high-technology diesel that delivers.

A turbo diesel engine is available across the HiAce range and this engine is purpose built for commercial vehicles – they're yet another powerful reason to choose HiAce.

The direct injection turbo diesel engine produces 80kW at 3000rpm and a lofty 286Nm of torque between 1200 and 1600rpm. This flat torque curve means this engine keeps pulling its weight all the way up the rev range. Being a common rail diesel engine, fuel is pumped at extremely high pressure for better atomisation and lower fuel consumption. So you'll feel the benefit behind the wheel and on your bottom line. This twin cam engine design with electronic engine management ensures greater fuel efficiency, smoothness and quieter running. Optimum use of Exhaust Gas Recirculation (EGR) reduces and controls Nitrous Oxide emissions, while the electronic 'drive-by-wire' throttle system makes for easier driveability.



3.0 Litre Turbo Diesel engine.



2.7 Litre Petrol engine.





Commuter Bus model shown.

Smooth operator.

Nippy handling, safer cornering.

Toyota didn't just stop at high performing engines. Hard-working suspension and steering mean HiAce handles responsively, is quiet and is easier to get along with. So hopping from job to job will be a breeze. Power-assisted rack & pinion steering offers greater road feel and more precise turning in tight spots. The rack stroke and steering angle have been optimised to reduce the turning circle. An aerodynamic front bumper with air dams each side, plus careful suspension tuning have also enhanced straight line stability and turning. The double-wishbone type front suspension with long torsion bars offers a comfortable ride, maximising wheel travel and suspension life. So after long days in the saddle, you'll be pleased you're in a HiAce.

Smoother transmissions.

Whichever engine you choose, Toyota has developed transmissions perfectly suited to the engines. You have the option of a 5-speed manual transmission or there's also a 4-speed, electronically controlled (ECT) automatic transmission offering improved shift feel and reduced shift shock, for smoother acceleration. The gated shift ensures precise gear selection, and an electronic shift lock and key interlock mechanism aids safety. The shifter is conveniently located on the dash, so you can move around the cab easier.



Front suspension.



Rear suspension.





Long Wheel Base model shown.



Space travel.

With longer wheelbases than ever before, the LWB and SLWB HiAce models have incredible interior space. The more squared off overall body design not only looks more stylish and professional, it optimises the interior room. The radiator and engine has been pushed forward to optimise interior room, while the small bonnet allows easy checking of fluids. The smart body design of the LWB means a large 6.0 cubic metres of cargo capacity whilst the SLWB van, with its wider body and higher roof, has a full 9.8 cubic metres of cargo volume, making it the biggest HiAce van ever. Each vehicle's longer wheelbase

means the wheels are moved towards each end of the vehicle, which also means greater straight line stability.

Easy loading, fast getaways.

Let's face it, whenever you're unloading you're in a hurry, in a congested street or in a loading zone. To help make life easier, remote central locking is standard* and the side door openings have also been made considerably wide for easier kerbside access. In the SLWB, there are sliding doors on both sides, while three interior lights (two in the cargo area) help you see what you're doing after

dark. With HiLux's slim tail lights, the rear door opening is significantly wide for easier loading and unloading plus a strap* incorporated on the inside of the rear door of LWB and SLWB vans helps you with pulling down the rear door when you're done. Additionally, on every model, drivers have a rear door mounted reversing mirror for added vision.

Comfort without stops.

Hard working days will no longer be hard labour. Air conditioning with a clean air filter* is fitted as standard, while the ease of power steering



Long Wheel Base interior model shown.



Super Long Wheel Base cargo interior shown.



Optimum storage and convenient access. SLWB model shown.



Folding centre seat back (Van models only).



LWB and SLWB models shown.

and supportive seats help reduce fatigue. In the Commuter Bus, passengers will enjoy a rear cooler ventilation system with overhead directional outlets. The ergonomic three-dial instrumentation cluster has two electric trip meters for mileage checking and power front windows make paying tolls less taxing. There are plenty of storage recesses to reduce cabin clutter, with document or map storage in the moulded front door pockets and glovebox. The centre seatback on van models folds forward, offering a handy table with two cupholders for your lunch, or a foldout tray to hold order books

or clipboards. If you get thirsty, retractable dual cupholders in the dash and bottle holders built into the front door trims help keep your drinks secure.

The HiAce's audio system with AM/FM radio and MP3 compatible CD player with Audio Input Jack[^] comes with two door-mounted speakers (four speakers in the bus) and offers easy listening, while full length headlining reduces ambient noise.

The Audio Input Jack allows for easy connection of your iPod[®] or portable MP3 player to provide

you with plenty of music choice for those long days on the road.

[^] From January '07 production

* From September '07 production





Super Long Wheel Base model shown.



Long Wheel Base model shown.

Safer working conditions.

This latest generation HiAce benefits from Toyota's two decades spent developing safer chassis design for 'one-box' (from vans to people movers) vehicles. The most advanced Computer Aided Engineering (CAE) tools were employed to develop an entirely new body design. This helped HiAce achieve excellent safety. Tests included Full Lap Front Collision Impact Testing and Offset Deformable Barrier Testing for the Van and Bus. Numerous reinforcements are integrated at key locations throughout the body design. A unique vertical Y-frame or 'crocodile' design of the front chassis rails helps absorb impact energy. Front upper members increase impact absorption ability. The front frame members have been straightened to increase impact absorbing ability. Side members are double layered to disperse and absorb crash impact energy.

There are front bumper reinforcement and reinforcement beams in the front doors. Toyota even went as far as developing a mechanism which moves the brake booster away in a collision. Standards of occupant restraint have also been increased. Dual front SRS airbags are fitted as standard, plus the driver and front passenger seats have Emergency Locking Retractor (ELR) type seatbelts.* They incorporate pre-tensioners which lock up in a collision and force limiters to relieve the pressure on the upper torso.* In the Commuter Bus, all 14 seats have lap

sash seatbelts.

Superior active safety systems.

Hard-working brakes, impressive handling, dynamic stability and reduced chance of driver fatigue are just some of the ways Toyota helps you avoid danger. Anti-skid Braking System (ABS) with Brake Assist (BA) which supplements your braking effort during sudden stops is available as an option.

Non-ABS brake systems include a load-sensing proportioning and bypass valve, which helps regulate braking effort depending on cargo load.

*Not fitted to centre seatbelt on Van models

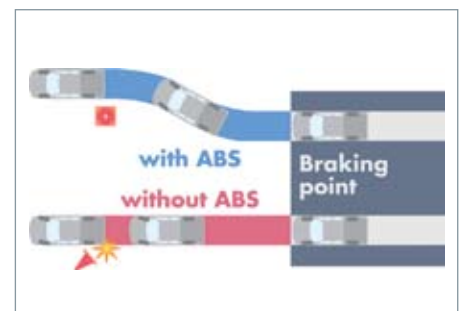

Anti-skid Braking System – Optional.



Dual front SRS airbags.

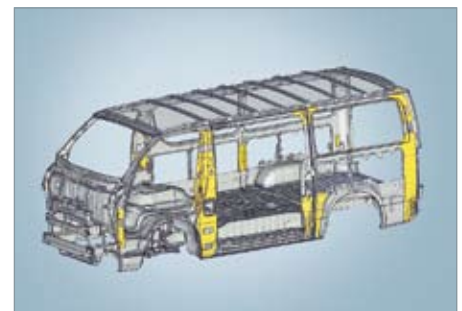

High-rigidity body.



The HiAce Range.

LWB Van

- 2.7L Petrol engine with VVT-i or a 3.0L Turbo Diesel engine with Intercooler
- LPG compatible Petrol engine (LPG system is available at extra cost)
- 6 cubic metres of cargo volume
- Driver and front passenger SRS airbags
- Air conditioning
- Power windows
- Remote central locking*
- MP3 compatible CD player with Audio Input Jack^
- Fold down centre seat/console with fold out tray and cup holders
- 'Headlights on' and 'key in ignition' warning buzzers
- Engine Immobiliser

SLWB Van

- 2.7L Petrol engine with VVT-i or a 3.0L Turbo Diesel engine with Intercooler
- LPG compatible Petrol engine (LPG system is available at extra cost)
- 9.8 cubic metres of cargo volume
- Driver and front passenger SRS airbags
- Air conditioning
- Power windows
- Remote central locking*
- MP3 compatible CD player with Audio Input Jack^
- Fold down centre seat/console with fold out tray and cup holders
- 'Headlights on' and 'key in ignition' warning buzzers
- Engine Immobiliser

Commuter Bus

- 2.7L Petrol engine with VVT-i or a 3.0L Turbo Diesel engine with Intercooler
- LPG compatible Petrol engine (LPG system is available at extra cost)
- 14 seats including driver
- Fold up last row seats for increased storage
- Driver and front passenger SRS airbags
- Front air conditioning with rear cooler
- Power front windows
- Remote central locking*
- MP3 compatible CD player with Audio Input Jack^
- 4 speakers
- 'Headlights on' and 'key in ignition' warning buzzers
- 3 point ELR seatbelts for all rear seats
- Engine Immobiliser

^ From January '07 production

* From September '07 production

HiAce. Toyota Genuine Accessories.



Accessories make a good thing even better.

HiAce featured is accessorised with Full Technician Kit Roof Rack, Alloy Nudge Bar, Cargo Barrier, Front Weathershields, Headlamp Covers and All Weather Rubber Floor Mats.

THESE ARE JUST SOME OF THE ACCESSORIES AVAILABLE FOR YOUR HIACE. FOR A COMPLETE LIST AND FURTHER DETAILS, PLEASE SEE YOUR TOYOTA DEALER OR REFER TO OUR WEBSITE.



ALLOY NUDGE BAR
Available on all models



CARGO BARRIER
Available on LWB & SLWB



FRONT WEATHERSHIELDS
Available on all models



ALL WEATHER RUBBER FLOOR MATS
Available on all models



ROOF RACKS - FULL TECHNICIAN KIT
Available on LWB



ROOF RACKS - STANDARD KIT
Available on LWB



TOWBAR WITH REAR CORNER PROTECTOR*
Available on all models



TOWBAR WITH REAR STEP AND PROTECTOR*
Available on all models



HEADLAMP COVERS
Available on all models



TOWBAR WITH TECHNICIAN STEP
Available on LWB



SATELLITE NAVIGATION^ AUDIO SYSTEM
INCLUDING 4 DISC IN-DASH MP3 COMPATIBLE CD CHANGER WITH BLUETOOTH™† COMMUNICATIONS AND (OPTIONAL) AUDIO INPUT
Available on all models



6 DISC IN-DASH MP3 COMPATIBLE CD CHANGER WITH BLUETOOTH™† COMMUNICATIONS AND AUDIO INPUT
Available on all models

TOYOTA GENUINE ACCESSORIES WITH OUR TOYOTA WARRANTY*

Some Toyota Genuine Accessories are not applicable to all HiAce models. Please refer to the Accessories Guide. All accessories are subject to availability. See your Toyota Dealer for details. Pictured Accessories are all sold separately. For a comprehensive guide on the entire range of Toyota Genuine Accessories, vehicles, merchandise and a whole lot more, visit our Website at toyota.com.au

*Towbar capacity subject to regulatory requirements, towbar design, vehicle design and towing equipment limitations.

**All Toyota Genuine Accessories purchased and fitted to a Toyota are warranted for the remainder of the New Vehicle Warranty or 12 months, whichever is greater. Toyota Genuine Accessories purchased from an authorised Toyota Dealer over the counter are warranted from the date of purchase for one year (unlimited kilometres). Conditions apply. All warranties are additional to the implied warranties under the Trade Practices Act 1974.

^Current mapping database encompasses major capital and primary national road networks as well as offering some coverage in regional areas.

†Bluetooth™ will only operate with telephones enabled with compatible Bluetooth™ wireless technology (HFP [Hands Free Profile] version 1.0 and OPP [Object Push Profile] version 1.1 international standards).

**Refer to your Apple iPod® Instruction Manual. iPod® is a registered trademark of Apple Computer Australia Pty Ltd. This accessory is not a Toyota Genuine Accessory (supplier branded) and is warranted for 12 months from the date of purchase. This warranty is additional to the implied warranties under the Trade Practices Act 1974.



AUDIO CABLE AND CAR CHARGER FOR IPOD®***
Available on selected models where AUX-in option is part of audio unit. Suits iPod® models that have a dock connector

TOYOTA GENUINE
PARTS, SERVICE & ACCESSORIES



TOYOTA ON THE WORLD WIDE WEB

For a comprehensive guide to the entire range of Toyota vehicles, accessories, merchandise and a whole lot more, visit our Internet site at: toyota.com.au

AT TOYOTA, WE'RE HERE FOR THE LONG RUN

The Toyota Long Run Warranty – every new Toyota is proudly backed by a 3 year/100,000km warranty which provides you with peace of mind and care free motoring (conditions apply).

TOYOTA GENUINE SERVICE

The advanced engineering and technology of every new Toyota is best maintained by the specialist skills only a Toyota Service Centre can provide. Toyota trained technicians have intuitive knowledge and use state-of-the-art diagnostic equipment to ensure your Toyota is serviced for optimal performance, efficiency and longevity. The use of Toyota Genuine Parts with a 12 month, unlimited kilometre warranty[#] gives you further security and peace of mind – all of which adds up to a genuinely better service.

TOYOTA GENUINE ACCESSORIES

When you choose Toyota Genuine Accessories you're adding even more personality, protection and practicality to your Toyota – tailoring it to your individual lifestyle needs. Toyota Genuine Accessories are designed, tested and manufactured to strict Toyota Standards. This quality and reliability is supported with our Toyota Warranty.* For customised fit, and real peace of mind, keep the feeling 100% Genuine, keep your Toyota all Toyota.

TOYOTA EXTRA CARE

Toyota Extra Care provides a wide range of Warranty and Roadside Assist solutions to provide you with protection for your Toyota so you can enjoy worry free motoring.

Extended Warranty

Whether your Toyota is new or used, a Toyota Extra Care Extended Warranty can help protect you from big repair bills and rising costs for years to come.

- Offers new Toyota vehicle owners the opportunity to extend the original Toyota warranty
- Includes additional items such as towing, car hire and accommodation
- Choice of 1, 2 & 3 year extended warranty plans available
- No excess to pay

If you have not purchased an Extended Toyota Warranty at the time of vehicle purchase, we can offer you a Toyota Approved Warranty Insurance** which offers the same features and benefits. Toyota Approved Warranty Insurance must be purchased prior to the expiry of your new vehicle warranty.

Depending on how the vehicle is to be used, not all customers will be eligible to purchase Extended Warranty, eg. taxis, rental and courier vehicles.

Roadside Assist

Toyota Extra Care Roadside Assist provides you and your family with access to emergency roadside assistance 24 hours a day, 7 days a week, 365 days a year, giving you total peace of mind. You can choose between the Standard plan or the Plus plan for additional benefits.

For more information on Roadside Assist or any of the Toyota Extra Care range of products, please contact your participating Toyota Dealer or call us on 137 200, 8.30am to 6.00pm (EST) Monday to Friday or visit www.toyotaextracare.com.au.

TOYOTA INSURANCE**

Toyota Insurance provides reliable and cost effective protection for the things that are important to your life such as your Toyota vehicle.

Motor Vehicle Insurance**

Toyota Insurance's Comprehensive Motor Vehicle Policy is tailored specifically for Toyota customers. Key benefits include:

- Replacement of your Toyota if it is a total loss (for Toyota vehicles up to 3 years/ 100,000 kms)
- Toyota Genuine parts guarantee and a lifetime guarantee on workmanship on all repairs for Toyota vehicles (when repaired at a Toyota Insurance Approved Repairer for as long as you own the vehicle)
- No Claims Bonus Protection
- 24 hours, 7 days a week access to claims customer service and "at scene" driver accident assistance

In addition, if your Toyota vehicle is equipped with Toyota Link and is stolen, the standard policy excess will be waived (subject to the terms & conditions of Toyota Insurance Motor Vehicle Insurance Policy).

For more information on Toyota Insurance** products, including Motor Gap Insurance and Payment Protection Insurance, please contact your participating Toyota Dealer, call us on 137 200, 8.30am to 6.00pm (EST) Monday to Friday or visit www.toyotainsurance.com.au

TOYOTA FINANCIAL SERVICES

Toyota Financial Services is here to help you with a range of easy vehicle finance options that can help you get in the driving seat faster. Whether it's a new or used vehicle, or a range of vehicles, we can tailor a personal or business finance solution to suit you.

We have numerous financing options to suit your particular income, taxation and structural requirements. Whether you require a simple consumer loan, a novated lease for you or your employees, or serviced leasing on your small-business tool of trade vehicles.

For further information on our range of finance options or to discuss the best option for you, please contact your participating Toyota Dealer or call us on 137 200, 8.30am to 6.00pm (EST) Monday to Friday, or visit www.toyotafinance.com.au

Toyota Financial Services is a division of Toyota Finance Australia Limited ABN 48 002 435 181.

IMPORTANT NOTICE – PLEASE READ: Toyota Australia uses its best endeavours to ensure brochure information is correct when published. When ordering accessories, you must check with your Toyota dealer to ensure the accessory's design, features and colours are available and will fit your vehicle. Accessory colours displayed here are a guide only and may vary from actual colours due to printing / display process. Toyota Australia reserves the right to change, without notice, at any time prices, colours, materials, equipment, specifications and discontinue colours/models. To the extent allowed by law, Toyota Australia will not be liable for any damage, loss or expense incurred as a result of reliance on this brochure. Distributed nationally by Toyota Motor Corporation Australia Limited ABN 64 009 686 097 155 Bertie St, Port Melbourne 3207.

[#]Conditions apply. All warranties are additional to implied warranties under the Trade Practices Act 1974.

*All Toyota Genuine Accessories purchased and fitted to a Toyota are warranted for the remainder of the New Vehicle Warranty or 12 months, whichever is greater. Toyota Genuine Accessories purchased from an authorised Toyota Dealer over the counter are warranted from the date of purchase for one year (unlimited kilometres). Conditions apply. All warranties are additional to the implied warranties under the Trade Practices Act 1974.

**Insured by Aioi Insurance Co. Ltd. (Aioi), a member of the Toyota Group of Companies. A Product Disclosure Statement (PDS) is available from participating Toyota Dealers or from Toyota Insurance by calling 137200. You should consider the PDS before making a decision about this product.

Distributed nationally by Toyota Motor Corporation Australia Limited. ABN 64 009 686 097. Cnr Gannons Rd & Captain Cook Drive Caringbah, NSW 2229. Part No. HIACE1107. Printed November 2007.

 **TOYOTA HIACE**
oh what a *feeling!*

