

Citroën Relay

THOR
dropside



24 Hours Parts Support

Bolted Construction

3 Year Warranty

Prefinished Components

Fit-While-Wait



INGIMEX

www.ingimex.com

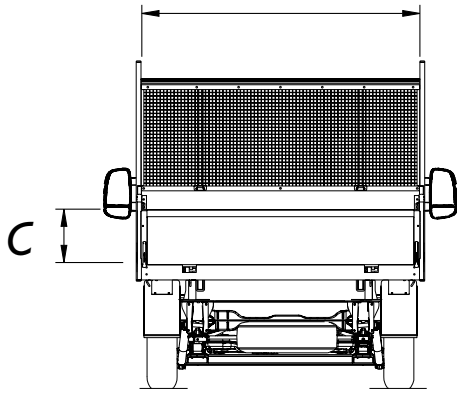
B

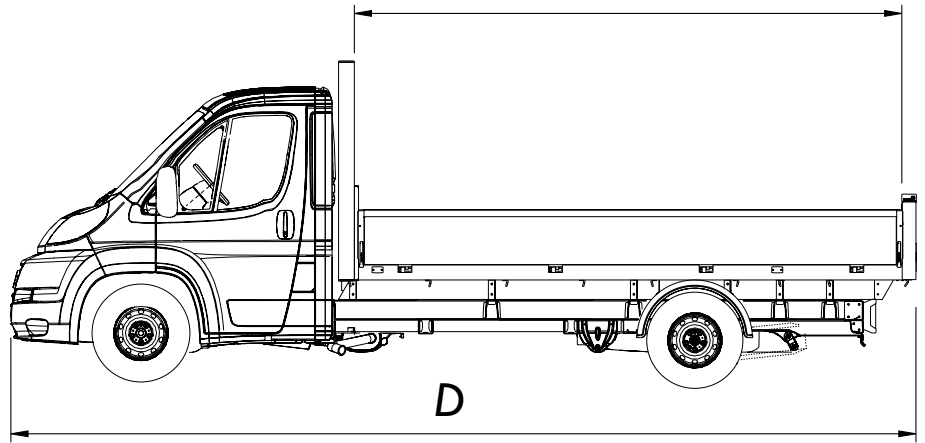

A



Citroen Relay Thor
dimensions in mm

Wheel Base	L2	L2.s	L3	L4	L4 D/Cab
(A) Length Int.	TBA	TBA	3674	4039	TBA
(B) Width Int.	TBA	TBA	2026	2026	TBA
(C) Sides & Tail Height	TBA	TBA	408	408	TBA
(D) Overall Vehicle Length	TBA	TBA	6230	6594	TBA

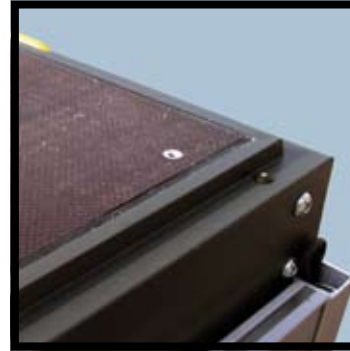

Top fitted one piece 15 mm phenol resin deck



Under body hooks for additional load securing flexibility



Flush fitting, discrete sideboard locks

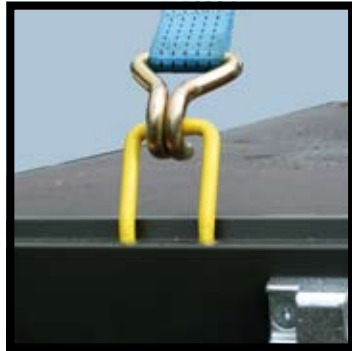

Rave mounted, clog resistant load lashing rings



Four bulkhead load lashing points



Removable rear corner post with tailboard restraint cords

The Ingimex Thor dropside is now available on the Citroën Relay as part of the Citroën Ready to Run conversion Scheme.

The exceptionally robust Thor body incorporates a range of operational and safety features not available elsewhere. The clever application of modern materials and finishes ensure a long and safe service life.

Standard features include 15 mm one-piece deck, recessed lashing rings, tail board restraint cords, flush fitted side and tail board locks and much more.

For further details, please contact sales@ingimex.com.

Ingimex Ltd.
Halesfield 19, Telford,
Shropshire TF7 4QT
Great Britain

Tel: +44 (0)1952 585833
Fax: +44 (0)1952 580940



FM 12348
ISO 9001 : 2000

www.ingimex.com
sales@ingimex.com

Ingimex reserves the right to make such changes to this specification as it thinks appropriate in pursuance of its policy of continuing development. For a copy of Ingimex Standard Terms & Conditions of Sale, go to www.ingimex.com or contact one of our sales staff.